

CUYAHOGA COUNTY
BOARD OF HEALTH
YOUR TRUSTED SOURCE FOR PUBLIC HEALTH INFORMATION

5550 Venture Dr · Parma, OH 44130 · 216-201-2000 · www.ccbh.net

License

A food vendor is required to make application for a temporary license at least ten (10) days before the start of the event. The application must include a floor plan, list of equipment, a menu, and all pertinent food handling procedures. **The temporary food license fee is \$70.00 per day and \$35.00 per day for non-profit operations.** Temporary food licenses are issued for a maximum of five (5) days. A sanitarian from the Cuyahoga County Board of Health (CCBH) will deliver the license on the first day of the event when they are on-site to conduct the inspection. Operators selling foods that are not time and temperature controlled for safety (TCS), such as whole fresh fruits and vegetables, commercially pre-packaged foods, commercial beverages, and cottage foods are exempt from licensing. (Some restrictions apply).

Food

All food must be from an approved source. Food not prepared on-site at the temporary food operation location shall be prepared in a licensed facility and transported to the temporary site by a method approved by CCBH. Foods shall not be prepared at home. Exceptions include cottage foods and home bakeries.

Food Protection

- A. All TCS foods shall be maintained at 41°F and below or 135°F and above. Mechanical refrigeration shall be used for overnight storage of all TCS foods.
- B. Frozen foods are to be thawed utilizing acceptable methods.
- C. Foods must be protected at all times. Covers or approved food shields must be utilized for any open or exposed food displays.
- D. Food and food containers shall be stored a minimum of six (6) inches above the floor or ground.
- E. Utensils and non-latex gloves shall be provided and utilized for the transfer, preparation and/or serving of foods.
- F. Provide and use a properly calibrated probe thermometer to verify cooking and holding temperatures.

Equipment, Utensils and Supplies

Depending on the type of foods, methods of transport, preparation and hot/cold holding, all or some of these items are required:

- A. **Handwashing facilities.** Method will be approved by CCBH based on the type of food and preparation.
- B. **Three compartment sink** or equivalent (three bucket system).
- C. **Sanitizer with test strips** [chlorine (bleach 5.25% concentration), quaternary ammonium, or iodine].
- D. **Probe thermometer(s).** For use if handling or preparing TCS foods.
- E. **Hot and cold holding equipment** (coolers, refrigerators, grills, etc.)
- F. **Utensils and disposable non-latex gloves.**

Structural Requirements

If it is determined by CCBH that floors, walls or ceilings are necessary, the materials used must be smooth, impermeable and easy to clean.

Support Facilities

Water is to be provided from an approved source only.
Adequate sewage / wastewater disposal site(s) must be available.
Portable toilet facilities, hand sinks, and garbage/refuse disposal are required.

CUYAHOGA COUNTY BOARD OF HEALTH

TEMPORARY FSO CHECKLIST

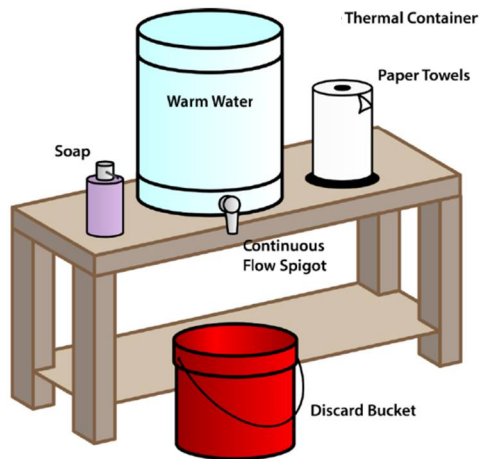

Approved Hand Washing

Each temporary booth is required to have a temporary hand washing station which includes: Warm flowing water, soap, paper towels, and a bucket for waste disposal.

***Hand sanitizer is NOT to be used as a substitution**



ALL foods must come from an approved source.
ALL foods are to be prepared at the event or at a licensed kitchen.

***HOMEMADE FOODS ARE PROHIBITED**

Exemption: cottage foods and home bakeries



Support Facilities

Make portable toilet facilities, hand sinks and garbage disposal available for patrons. Water shall be provided by an approved source. All waste water is to be discarded to the sanitary sewer.

***Dumping grey water in storm drains or on the ground is not an approved form of disposal**



Approved Method for Sanitizing Equipment & Utensils

A three compartment sink must be provided to properly wash, rinse and sanitize all equipment (must be able to fit largest piece of equipment.)

***Approved sanitizers and concentrations: Chlorine 50-99ppm, Quaternary ammonium 200-400ppm or Iodine 12.5-25ppm**



Approved Cooking & Holding Temperatures

- Cold Holding 41°F & below
- Hot Holding 135°F & above
- Chicken Cooking 165°F
- Ground Beef Cooking 155°F
- Seafood/Roasts/Chops Cooking 145°F
- Fruits and Vegetables Cooking 135°F

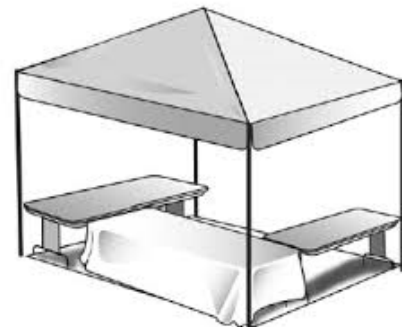

Work Space Requirements

Work surfaces shall be easily cleanable & non-absorbent. Flooring shall be provided if booth is placed in grass. All foods, utensils and equipment must be 6" off of the ground.

Application for a License to Conduct a Temporary: (check only one)

Instructions:

1. Complete the applicable section. (Make any corrections if necessary.)
2. Sign and date the application.
3. Make a check or money order payable to: **Cuyahoga County Board of Health**

- Food Service Operation
 Retail Food Establishment

4. Return check and signed application to:

Cuyahoga County Board of Health
Attn: Environmental Public Health
5550 Venture Dr.
Parma, OH 44130

Temporary Applications Must be Submitted Ten (10) Days Prior to the Event for Approval

Before a license application can be processed and approved, the application must be completed and the required fee submitted. This action is governed by Chapter 3717 of the Ohio Revised Code.

Name of temporary food facility		
Location of event		
Address of event		
City	State	ZIP
Start date	End date	Operation time(s)
Name of license holder		Phone number
Address of license holder		
City	State	ZIP
List all foods being served/sold		

<i>I hereby certify that I am the license holder, or the authorized representative, of the temporary food service operation or temporary retail food establishment indicated above:</i>	
Signature	Date

Licenser to complete below

Valid date(s)	License fee:
---------------	--------------

Application approved for license as required by Chapter 3717 of the Ohio Revised Code.

By	Date
Audit no.	License no.

TEMPORARY FOOD SERVICE INFORMATION

1. Food

- A. If food is prepared in advance, how is it transported and where was it prepared? (Food must be prepared at a licensed facility or prepared at the event)

- B. How will foods be held hot (135°F and above)

- C. How will foods be held cold (41°F and below)

THERMOMETERS MUST BE AVAILABLE TO ENSURE PROPER COOKING AND/OR HOLDING TEMPERATURES. A THERMOMETER MUST HAVE THE AVAILABILITY TO MEASURE TEMPERATURES FROM 0-220°F. (LASER THERMOMETERS ARE NOT SUFFICIENT.)

2. Sanitation

- A. How will food handlers wash their hands at this temporary location? (Hand washing facility is required to be at each temporary location)

- B. How & when will equipment and utensils be washed? (Include type of sanitizer)

- C. How will the concentration of the sanitizer be measured?(Include type of test kit)

- D. Water source? (Where is the water coming from)

- E. Where will waste-water be discarded? (Not on ground or storm drain)

3. Food Protection

- A. How will food on display be protected from contamination?

- B. Will employees use utensils or gloves to prepare the food? (Latex gloves are prohibited)

- C. How will employees restrain their hair? (Hats, beard covers, hairnets)

4. Drawing of Layout

A. Example

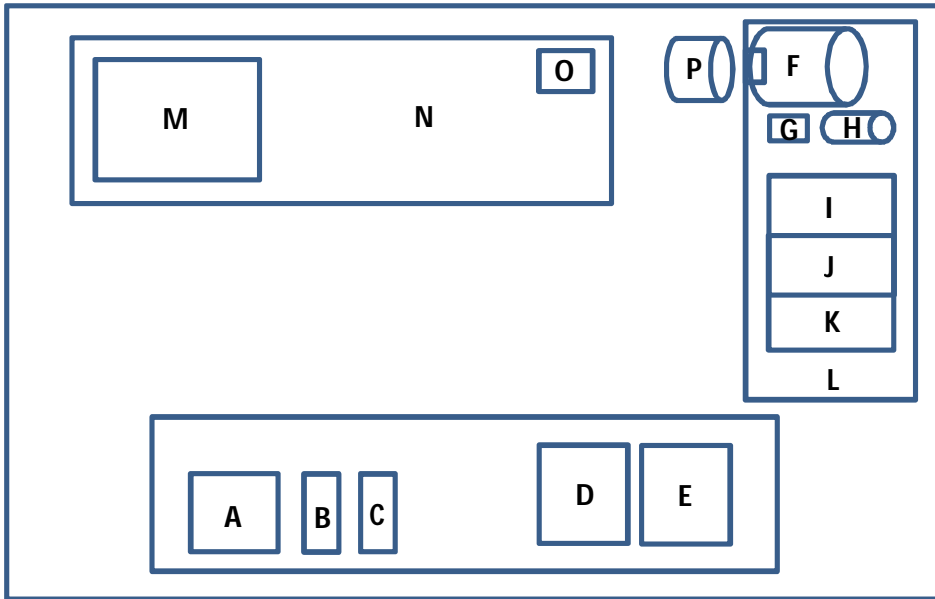

Legend

- A. Cash Drawer
- B. Napkins
- C. Utensils
- D. Hot chocolate
- E. Coffee
- F. Warm water
- G. Soap
- H. Paper towels
- I. Wash
- J. Rinse
- K. Sanitize
- L. Drying area
- M. Hot holding unit
- N. Working area
- O. Gloves
- P. Bucket for gray water collection

B. Provide a detailed drawing of your floor plan. Show all equipment and utensils, support facilities, and serving areas.

