

# CUYAHOGA COUNTY BOARD OF HEALTH

YOUR TRUSTED SOURCE FOR PUBLIC HEALTH INFORMATION

## Temporary Park Camp Requirements

As defined in Ohio Revised Code 3729.01 (V), a “temporary park camp” is any tract of land used for a period not to exceed a total of twenty-one days per calendar year for the purpose of parking five or more recreational vehicles, dependent recreational vehicles, or portable camping units, or any combination thereof, for one or more periods of time that do not exceed seven consecutive days.

### Plan Review

A set of plans must be submitted to the Cuyahoga County Board of Health at least fifteen (15) days prior to the event, and must contain the following in order to gain approval:

- Two sets of drawings, which depict all items as described in the plan review application (form HEA 5213), under section 3701-25-52 of the Ohio Administrative Code.
- Written documentation from the local Fire Department for verification that the camp has proper and sufficient fire protection. Note: Documentation may be in the form of an email directly from the Fire Department, or hard copy letter on the Fire Department’s letterhead.

### Licensure

Once the plans are approved, the camp will be approved for licensure. In order to be licensed, a license application (Form HEA 5336) must be completed and submitted with the \$130.00 application fee.

**Note:** Temporary park camp plan review and licensing applications may be found at [www.ecbh.net](http://www.ecbh.net).

### Operational Requirements

- Compliance to all regulations described in this document.
- All park/camp buildings, sites, and facilities shall be maintained in a safe and sanitary manner at all times.
- The park/camp shall be properly drained to eliminate standing water, and free from all trash and debris.
- Pests and other nuisances shall be prevented and abated immediately if they occur.
- All roads and walkways shall be maintained.

### Spacing

The minimum spacing requirements for recreation vehicles are highlighted below:

Sites must be at least 1,000 ft<sup>2</sup> in size.

Camping units shall be parked only on sites that comply with approved plans.

Vehicles may be parked in between RVs without affecting distance requirements.

Recreational Vehicles	Minimum Spacing
<b>Side to Side</b>	15 Feet
<b>End to Side</b>	10 Feet
<b>End to End</b>	10 Feet
<b>From any Building</b>	15 Feet
<b>From any Public Road</b>	15 Feet
<b>From Park/Camp Roads</b>	10 Feet
<b>From Property Lines</b>	7.5 Feet

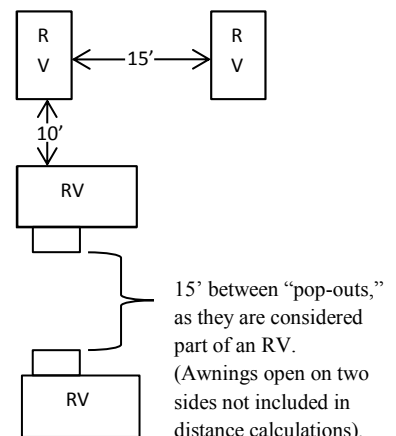

## Water

It is not required that water be provided at the camping sites. However, if water is provided, it must meet Ohio EPA requirements.

If water is provided, the hoses connecting the units to the water supply must be National Sanitary Foundation (NSF) 61 approved hoses for drinking water.

In order to prevent contamination of the water supply, approved backflow prevention must be utilized at the main water source. ASSE-1013 backflow prevention assemblies and ASSE-1024 dual check valve backflow prevention devices at individual connection points (or their equivalents) are acceptable.

## Sewage/Wastewater

Adequate sewage/wastewater disposal must be provided by using a combination of the following:

- A designated dump station
- Individual watertight containers at each site
- The services of a registered sewage hauler to pump out RV tanks

**NOTE:** It is critical that sewage/wastewater not be disposed of on the grounds or into storm sewers, as this could directly contaminate natural waterways.

## Toilets

Toilets must be provided as indicated in the chart below:

Sites #	Men		Women
	Urinals	Toilets	Toilets
5-15		1	1
16-30	1	1	2
31-60	1	2	3
61-90	2	2	4
91-120	2	3	5
121-150	3	3	6
151-200	4	4	8
201-300	5	5	10
301-400	6	6	12
401-500	7	7	14
501+ Add 1 per 200 for men and 2 per 200 for women			

Toilets must be located within 1,000 feet walking distance from camp sites.

## Trash

Trash containers must be provided for proper disposal of trash and waste. Sufficient capacity and pickup must be met so dumpsters do not overflow. Dumpster lids must remain closed when not in use. **Note:** In order to prevent the attraction of pests, it is critical that all trash be properly contained/not left on the grounds.

## Safety

Fire-fighting equipment of the type and quantity acceptable to the State of Ohio Fire Marshal or local Fire Department shall be made available for use in firefighting. All firefighting equipment shall be maintained in good operating condition (not expired), and located so it is easily accessible at all times.

If the Cuyahoga County Board of Health believes an electrical hazard exists, the operator will be required to provide written documentation indicating that all electrical systems at the park/camp meet applicable state and local electrical codes.

First aid equipment consisting of disposable gloves, a sufficient supply of materials to stop bleeding, and to clean and cover minor cuts and abrasions shall be maintained and easily accessible.

The operator shall maintain a record of all injuries occurring within the park requiring the attention of medical personnel licensed under Chapters 4723, 4730, and 4731 of the Ohio Revised Code.

The operator shall ensure that no motorized vehicles are operated in such a manner as to create hazards to life and safety.

The operator shall identify all natural hazards within the park/camp and eliminate them whenever possible.

Firearms and other potentially hazardous equipment and substances shall be used, stored, and maintained in a safe manner.

The operator shall control any potentially hazardous activities or excessive noise within the park/camp.

#### **Animals/Pets**

The operator shall promptly report all cases of domestic and wild animal bites within the park/camp to the local animal control official and the Cuyahoga County Board of Health at 216-201-2000.

#### **Animal Venues**

In order to minimize the safety risks associated with animals in public settings, the Cuyahoga County Board of Health operates the Animal Venue Program. "Animal venue" includes any operation that sells, distributes or exhibits animals to the public. If an animal venue is associated with your event, please visit [www.ccbh.net/animal-venues](http://www.ccbh.net/animal-venues), and download an application for an animal venue permit at least one week prior to the event. If you have any questions regarding animal venues, please contact Program Manager, Stacey Short R.S., MPH, at 216-201-2000 x1253 or [sshort@ccbh.net](mailto:sshort@ccbh.net).

**If you have any questions regarding the Temporary Park Camp Program, please contact:**

**Jim Armstrong, R.S., MS**

Program Manager

216-201-2001 x1251

[jarmstrong@ccbh.net](mailto:jarmstrong@ccbh.net)

# Application for License To Operate a Temporary Park-Camp

		License valid	From:
			To:
<b>Camp Name</b>		<b>Health District</b>	
Street Address		<p align="center"><b>Directions: (please print)</b></p> <p><b>1. Complete <u>one</u> application for each licensed establishment;</b></p> <p><b>2. Sign and Date the application</b></p> <p><b>3. Attach a check or money order and return according to the information listed below.</b></p>	
City/Zip			
Phone #	Phone #		
<b>Owner/ Licensee</b>			
Street Address			
City/ State /Zip			
Phone #	Phone #		
# of camp sites per approved plans	Water Supply : [ ] Community [ ] Other:		

**Person to Contact regarding inspections, maintenance, or emergencies, if different from licensee.**

Name	Phone #
Address	
City/Zip	

I hereby certify that I am the licensee, or the authorized representative of the establishment listed above, and agree to abide by the rules that apply for this license. I certify that the information provided is a true and accurate statement of the facts.

Signature	Phone #	Date
-----------	---------	------

**Check or money order for the license fee, payable to:**

**Return the fee and application to:**

Cuyahoga County Board of Health	Health District	
	Cuyahoga County Board of Health	
	Street address	
	5550 Venture Drive	
City		
Parma, Ohio		
Zip	44130	Phone #
		(216)201-2000

**LOCAL LICENSING AUTHORITY TO COMPLETE BELOW**

<b>License fee</b>	\$130.00	<b>Total amount due</b>	\$130.00
--------------------	----------	-------------------------	----------

**Application approved for license as required by Section 3729 of the Ohio Revised Code.**

By	Date
Audit No.	License No.

# SITE EVALUATION REPORT

To be completed by licensor having jurisdiction.

Authority: Ohio Administrative Code Chapter, 3701-26-03

TYPE OF PROJECT	
<input type="checkbox"/>	Recreation Camp (RC)
<input type="checkbox"/>	Recreational Vehicle Park (RVP)
<input type="checkbox"/>	Combined Park Camp (CPC)
<input type="checkbox"/>	*Temporary Campground (TPC)

*\*TPCs are the responsibility of the local health district.*

TYPE OF DEVELOPMENT	
<input type="checkbox"/>	New
<input type="checkbox"/>	Substantial Alteration

COUNTY		LOCAL HEALTH DISTRICT	
FACILITY NAME		OWNER	
STREET ADDRESS		STREET ADDRESS	
CITY, ZIP CODE		CITY, STATE, ZIP	
FACILITY PHONE NO.	FACILITY E-MAIL	OWNER PHONE NO.	OWNER E-MAIL

**I. Site Information/Conditions:**

A. Describe access thoroughfares on and adjoining the site: \_\_\_\_\_

B. Describe adjoining land uses: \_\_\_\_\_

C. Describe significant topographic features such as unusable land area, sharp changes in grade, waterways, or wetlands: \_\_\_\_\_

D. You may use the back of this form for additional remarks or to sketch the above or any other appropriate items.

E. Soil classification: list predominant soil types and characteristics (refer to the "Soil Conservation Service, Soil Survey"; \_\_\_\_\_

F. Research and comment on previous land uses to include, but not limited to, landfills or hazardous substance/disposal sites: \_\_\_\_\_

<p><b>II. Lot Information:</b></p> <p>Number of existing, fully developed lots: _____ (any lot a man. home can be placed/occupied)</p> <p>Total number of proposed lots: _____</p>	<p><b>III. Describe work proposed:</b></p> <p>_____</p> <p>_____</p> <p>_____</p>
--	---

**IV. Utilities** (check appropriate items):

A. Transmission lines: Existing Proposed No Indication

Electric \_\_\_\_\_

Gas, propane, fuel oil \_\_\_\_\_

Water \_\_\_\_\_

Sanitary Sewer \_\_\_\_\_

Storm sewer \_\_\_\_\_

B. Service systems: Public Private Other

Water ~~\_\_\_\_\_~~ \_\_\_\_\_

Sanitary ~~\_\_\_\_\_~~ \_\_\_\_\_

Campgrounds only:

Restroom(s) \_\_\_\_\_

Dump station(s) \_\_\_\_\_

Waste water drain(s) \_\_\_\_\_

Based on soil types in Sec. I E above, do you oppose use of a leaching type waste water drain(s)?  Yes  No

**Note:** New development or expansion may be subject to OEPA review and permits.

**V. Expansion/Substantial Alteration/New Development:**

A. Is the proposed development licensed by the licensor? ~~\_\_\_\_\_~~ Yes ~~\_\_\_\_\_~~ No

1. Verify the number of lots on the license permit with section II above, and with previously approved plans, plan approval letters, and plan extension approval letters.

B. Comment on the compliance of the existing facilities to the appropriate rules. \_\_\_\_\_

C. Objections to development of the existing or proposed project. \_\_\_\_\_

SANITARIAN	DATE
------------	------